

"Education is the most powerful weapon which you can use to change the world."

MHT CET 2025 Latest News and 50% Increase in Women's Higher Education in India: Why Are Engineering and IT Still Missing Out? Update

While the number of women pursuing higher education in India has been steadily increasing, a noticeable imbalance remains between those choosing engineering and technology-related fields and those opting for other areas of study. Data from the Indian government reveals that between the academic years 2013-14 and 2021-22, there was a substantial 46 percent rise in female enrollment in undergraduate programs, and an even more significant 55.5 percent increase in postgraduate programs. However, this overall growth in female participation in higher education is overshadowed by a decline in enrollment in engineering degrees

-VidyarthiMitra News Desk



Specifically, the data indicates a 1.35 percent decrease in women enrolling in undergraduate engineering courses and a much sharper 43 percent drop in postgraduate engineering programs. Looking at other disciplines, female enrollment in undergraduate commerce programs experienced a healthy 42 percent growth

Model School ADMISSION Notice & Form for the Academic session 2025-26 till last date as 10th March 2025

-VidyarthiMitra News Desk

The Reservation Policy of Government of India will be implemented for SC, ST, OBC and EWS/BPL. If seats remain vacant from any region then the seat will be allotted into other region. For the wide publicity of the new admissions in MSVH, the School will try to approach to all the Education Secretaries in various states of India and advertisement will be published in National Newspapers also. The medium of instruction during teaching will be only Hindi and English. Admission procedure for class XI (Science Stream only) will be finalized after declaration of class X result (CBSE). Students can submit their mark sheet at the time of admission. Admission form can be obtained from the website <https://niepvd.nic.in/> & <https://msvh.niepvd.in/> of the Institute. Admission form duly filled must reach the school office by 10th March 2025 through offline mode (by hand/Speed Post). Admission form received after 10th March 2024 will not be entertained

Note APAAR ID is mandatory for all the students excluding Bal Vatika. APAAR ID can be obtained from previous School of the ward. Hostel facility will not be provided to non PwD students. S.No. Class (Foundational stage) No. of seats Age Region (East, west, north, south) 1 Bal Vatika 10 05 to 06 years 2 Standard I 07 06 to 07 years 3 Standard II 05 07 to 08 years S.No. Class (Preparatory stage) No. of seats Age Region (East, west, north, south) 1 Standard III 03 08 to 09 yrs 2 Standard IV 01 09 to 10 yrs 3 Standard V NIL 10 to 11 yrs The above mentioned seats are the total vacant seats and the same will be divided into four regions of India i.e North, South, East and West.

Education Budget 2025-26 Receives Positive Industry Feedback

-VidyarthiMitra News Desk

The recently unveiled Union Budget 2025-26 has garnered praise from Dhruv Galgotia, CEO of Galgotias University, who lauded its commitment to bolstering India's education sector. Galgotia specifically highlighted the government's dedication to transforming India into a global knowledge hub, evidenced by increased budgetary allocations for both school and higher education.

The budget allocates a substantial Rs 128,650 crore to the Ministry of Education. Of this, Rs 78,572 crore has been earmarked for school education, while Rs 50,078 crore will support higher education initiatives. Galgotia emphasized the importance of several key initiatives within the budget, including Atal Tinkering Labs

the PM Research Fellowship Scheme, and the establishment of a Centre of Excellence in Artificial Intelligence. He believes these programs will significantly contribute to enhancing both learning outcomes and research capabilities within the country.

Galgotia also expressed his appreciation for the budget's focus on improving skilling programs and easing financial access to education. He noted that these measures are in close alignment with the goals and objectives outlined in the National Education Policy (NEP) 2020, suggesting a cohesive and strategic approach to educational reform. The CEO's positive response underscores the budget's potential to drive meaningful change and advancement within India's education landscape.

India's Higher Education Enrolment Makes Gains: Up from 23.7% to 28.4%

-VidyarthiMitra News Desk

The Economic Survey 2024-25 was introduced in Parliament by Nirmala Sitharaman, Union Minister for Finance and Corporate Affairs. According to the Survey, the National Education Policy 2020 (NEP) is founded on the idea that education and the development of human capital are essential to the advancement of the country.

UDISE+ 2023-24 reports that there are 98 lakh teachers and 14.72 lakh schools in India, serving 24.8 crore pupils. Of the total, 69 percent are government institutions, which employ 51 percent of teachers and enroll 50 percent of students. With 32.6 percent of kids enrolled and 38 percent of teachers employed, private schools make up 22.5 percent of the total.

By 2030, NEP 2020 aims to achieve a 100% Gross Enrollment Ratio (GER). With continuous attempts to close gaps at the secondary level (77.4 percent) and higher secondary level (56.2 percent), GER is almost ubiquitous at the primary level (93 percent). At 1.9 percent for primary, 5.2 percent for upper primary, and 14.1 percent for secondary education, school dropout rates have decreased.

Improvements have been made to school facilities, such as improved access to information and communication technologies and improved cleanliness. While internet access climbed from 22.3 percent to 53.9 percent during the same period, the percentage of schools with computers increased from 38.5 percent in 2019-20 to 57.2 percent in 2023-24.

Samagra Shiksha Abhiyan and its sub-schemes, such as NISHTHA, Vidya Pravesh, District Institutes of Education and Training (DIETs), and Kasturba Gandhi Balika Vidyalaya (KGBV), as well as initiatives like DIKSHA, STARS, PARAKH, PM SHRI, ULLAS, and PM POSHAN, are some of the programs and schemes the government is using to implement NEP 2020.

In April 2024, the government introduced the National Framework for Early Childhood Stimulation (Navchetana) and the National Curriculum for ECCE (Aadharshila) in an effort to improve ECCE. Aadharshila offers play-based learning activities for kids ages three to six, while Navchetana uses a 36-month stimulation cycle to help kids from birth to three years old.

Foundational Literacy and Numeracy (FLN) is a top priority for NEP 2020 since it is crucial for learning success. To guarantee that all students achieve FLN by Grade 3 by 2026-2027, the Department of School Education & Literacy launched the National Initiative for Proficiency in Reading with Understanding and Numeracy (NIPUN Bharat). One strategy utilized to accomplish this is peer teaching.

NEP 2020's ECCE program emphasizes socioemotional growth and basic literacy. Social-Emotional Learning (SEL), a strategy for integrating moral and emotional growth into the curriculum, is covered in the survey. With the advent of Industry 4.0, which places a strong emphasis on automation, artificial intelligence, the Internet of Things, big data, and robotics, skill education has become more important. Additionally, digital literacy is being included into the classroom to support students' growth in communication and analysis abilities. The government introduced TeacherApp, a digital professional development platform, to assist educators. Industry-relevant skills and certifications, individualized learning tools, and artificial intelligence (AI) for teacher development and student tutoring are the main areas of concentration for technology integration in education.

As the higher education industry changed, the number of institutions rose from 51,534 in 2014-15 to 58,643 in 2022-23.

Scan the QR to check our E-paper

Website

Admission Guidance

Option form Filling for college admissions, the latest cut-offs, College & Branch Selection etc.

[Enquiry Form](#)
[Educational E-Paper](#)
[Join Admission Guidance Whatsapp Group](#)
[Join Telegram Group](#)

IP University Admissions 2025: Online application begins on February 1- Key details of new courses

-VidarthiMitra News Desk

IP University Admissions 2025: Guru Gobind Singh Indraprastha University (GGSIPU) will start the admission registration procedure for the academic session 2025-26 on February 1, as per the notice issued by the varsity. The admissions to several undergraduate, Postgraduate, and PhD courses across the university will be done based on their CUET scores only. Remaining admissions will be conducted by the scores in the University's common entrance test (IPU CET) 2025. The classes will start from August 1, 2025.

Notably, the varsity will conduct the registration procedure for the 46 master's degree, 40 PhD, and 34 undergraduate programmes on February 1. Among these, 20 undergraduate and 18 postgraduate courses will be filled based on CUET scores. Additionally, one seat per programme is reserved for single girl child candidates in university schools and up to 2 percent of seats in each programme will be allocated under sports quota.

New courses details: This year, the university has released several new courses for the academic session 2025-26. The list of the latest courses offered is as follows.

- **MSc. in Molecular Diagnostics**
- **MSc. in Microbiology**
- **Bachelor in Physiotherapy (BPT)**
- **LLB (3-years)**
- **Applied Geoinformatics**
- **Radiological Physics (PG Diploma)**

1. IP University Admissions 2025: CET and counselling schedule

According to the notice, the varsity will conduct a common entrance test (CET) for 53 programmes from April 26 to May 18, 2025. The online counselling process for MBA programmes based on CAT scores, LLB, and LLM through CLAT UG/PG will commence on May 1 while Online and offline counselling for other programmes will start on June 2

Important things to note

Students who are seeking admission to IPU must keep the following details in mind.

- The total fee of Rs 2,500 will be paid during the online registration process. This includes the registration fee and counselling procedure.
- One seat in each programme is reserved for a single girl child candidate in university schools.
- 2 per cent of admission intake in a particular course will be based on the sports quota in university schools.

IIM Ahmedabad is accepting applications for its MBA-BPGP program until March 25, 2025.

-VidarthiMitra News Desk

IIM Ahmedabad has opened its application portal for the 2025 intake of its two-year Blended Post Graduate Programme in Management (MBA-BPGP). This program is specifically tailored for working professionals, entrepreneurs, and individuals aiming to enhance their management capabilities without taking a break from their current employment. Aspiring candidates can submit their applications through the official IIM Ahmedabad website, iima.ac.in, with the application window closing on March 25, 2025. Management (BPGP) is designed to

equip working professionals and entrepreneurs with a distinct competitive edge, enabling them to accelerate their career trajectories. The program aims to bridge the gap between theoretical knowledge and practical application, providing students with the tools and frameworks necessary to navigate the complexities of modern business. It also offers a platform for networking and peer learning, connecting participants with a diverse cohort of professionals from various industries and backgrounds.

B.Ed Admission Procedure 2025

-VidarthiMitra News Desk

Admission to B.Ed courses 2025 to top BE colleges one needs to prepare for entrance exams, and score well in them. Entrance exams are conducted at various levels including, national level, state level, and university level. Some of the commonly accepted entrance exams in 2025 include [Bihar B.Ed CET](#), [UP B.Ed JEE](#), [MAH B.Ed CET](#), [TSEdCET](#), [APEdCET](#), etc. B.Ed course admission eligibility requires one to complete 10+2 in any stream from a recognized board with an aggregate of 50% or more. Further, the admissions to BE

courses rose after the Government of India passed the New Education Policy. The policy emphasizes quality education for students creating the demand for more skilled teachers in the education sector. Moreover, B.Ed admission can be offered either after completing graduation or post-graduation in the relevant discipline and is also offered in integrated programs such as BA-B. Ed or B.Sc-B.Ed which can be pursued after Class 12th. The average fee ranges from INR 15,000 to INR 3 lakh depending on the institution.

ENTRANCE EXAM

Law Entrance Exams in India 2025

-VidarthiMitra News Desk

Several key law entrance exams are conducted in India for admission to prestigious law schools. The Common Law Admission Test (CLAT), conducted by the Consortium of National Law Universities, is one of the most sought-after exams for admission to 26 NLUs and other top law schools. It is usually held in the first week of December, with applications open from July to mid-November. Similarly, the All India Law Entrance Test (AILET) is conducted exclusively for admission to NLU Delhi. The exam is scheduled for the second week of December, and applications are accepted from August to mid-November.

Another important exam is the Law School Admission Test (LSAT) India, conducted by LSAC Global for admission to top private law schools such as Jindal Global Law School, BITS Law School, and Manipal University. It is held twice a year, in January and May, with applications opening in November. For students aspiring to study law in Maharashtra, the MH CET Law exam is an essential gateway for admission to 3-year and 5-year LL.B. programs in various state law colleges. The 5-year law program exam is scheduled for April 28, 2025, with application details to be announced soon.

JEE Advanced 2025 Exam Date Announced: Here is complete schedule

-VidarthiMitra News Desk

The Indian Institute of Technology (IIT) Kanpur has officially announced the date for the Joint Entrance Examination (JEE) Advanced 2025. As per the notification available on the official website, the examination will take place on Sunday, May 18, 2025. The exam will include two mandatory papers, each three hours long. Paper 1 is scheduled from 9:00 AM to 12:00 PM, and Paper 2 will be conducted from 2:30 PM to 5:30 PM.

"The JEE (Advanced) 2025 will be conducted on Sunday, May 18, 2025. The examination will consist of two papers (Paper 1 and Paper 2) of three hours each," states the official notice. The information brochure, expected to be published soon, will include comprehensive details about the application process, application fees, and the.

JEE Advanced 2025: Next Steps for Candidates

Aspirants are encouraged to visit the official JEE Advanced 2025 website regularly for updates. The institute has advised candidates to familiarize themselves with the eligibility criteria and syllabus in preparation for the examination.

JEE Advanced Eligibility and Syllabus Details :

IIT Kanpur has also provided updates on the eligibility criteria and syllabus for the exam. The Joint Admission Board (JAB) has reinstated the rule limiting the number of attempts to two. Only candidates who qualify for the JEE Main 2025 will be eligible to appear for the JEE Advanced 2025.

-VidarthiMitra News Desk

MHT CET 2025 Latest News and Updates:

- The application process for MHT CET 2025 commenced on December 30, 2024.
- MHT CET 2025 registration dates announced from December 30, 2024, to February 15, 2025.
- The authority has announced the MHT CET 2025 exam dates. The MHT CET 2025 for PCM will be conducted from April 19 to 27, 2025 (except April 24), while the PCB exam will be conducted from April 9 to 17, 2025 (excluding April 10 and 14).
- The Maharashtra State CET Cell has published the revised MHT CET 2025 syllabus and exam pattern on the official website.

MHT CET 2025 Latest News and Updates: The Maharashtra State CET Cell has commenced the MHT CET 2025 registration on December 30, 2024. The link for the MHT CET 2025 application form is available on the official website, cetcell.mahacet.org. The last date for the MHT CET 2025 application form is February 15, 2025. The MHT CET 2025 exam dates have been released on the official website. The Maharashtra CET entrance exam will be conducted in online mode. The MHT CET 2025 exam for PCM will be held between April 19 and 27, 2025, while the PCB exam will be held between April 9 and 17, 2025. This page will be updated with the MHT CET's latest news and updates 2025 as they are updated officially.

NEET UG 2025 News: Check Latest Exam Updates by NTA.

-VidarthiMitra News Desk

All the candidates who are preparing to appear in the NEET 2025 Exam are eagerly waiting for the NEET UG Exam Notification 2025 by NTA. The National Testing Agency, which is the conducting authority for the National Eligibility and Entrance Test, has published an official notification about the NEET 2025 registration date, exam date, etc. This article below shares all the latest updates regarding the NEET UG Exam 2025.

- The National Testing Agency has released the NEET 2025 Information Bulletin; according to it, the NTA has now added a few new tie-breaking rules.
- The NTA has decided to conduct the NEET 2025 Exam for a time duration of 180 minutes [3 hours], i.e., from 2:00 pm to 5:00 pm.
- As per the released notification, the NEET 2025 exam is scheduled to be held on May 4, 2025, for a time duration of 180 minutes.

The NEET UG 2025 Registration Last Date is March 7, 2025 [till 11:50 pm].

- The NEET UG 2025 Registration Date has been announced by the NTA at its official website on February 7, 2025.
- The NEET UG 2025 is going to be conducted for admission into 1,08,940 MBBS seats.
- Key Changes Introduced in the NEET 2025 Exam that Every Candidate Must Know Going into the Exam.

The NTA has revised the NEET Exam Pattern 2025, scrapping the optional questions and making it mandatory for aspirants to attempt all the 180 question asked in the question paper -

- The NTA is all set to make the announcement of the NEET Exam Date 2025 at its official website anytime soon. Candidates need to keep refreshing this page to get the NEET 2025 exam date and latest news.

A summer workcamp focused on nature and community is being offered in Germany.

-VidarthiMitra News Desk

A fully funded Nature Community Summer Workcamp in Germany offers a chance to experience the country while engaging in environmentally conscious activities and connecting with nature. Participants are encouraged to contribute and implement their own ideas for wildlife preservation, fostering both social skills and environmental responsibility.

This unique six-week program, housed in 15 bungalows, focuses on developing practical skills through various activities, including work in German forests. All necessary safety precautions and equipment will be provided. Participants are expected to dedicate themselves to nature conservation and making a positive impact. The workcamp promises a rewarding experience of learning, personal growth, and enjoyment.

Eligibility Criteria

- * Applicants must be between 18 and 30 years old.
- * Applicants must be citizens of an eligible European country.
- * No prior work experience is necessary.
- * Applicants must be motivated to participate.
- * No specific educational level is required.
- * Applicants can be from any field of study.
- * Applicants must be open to participating in environmentally friendly activities.

Benefits:

- * Accommodation will be provided, with participants sharing rooms with one or two other people.
- * Three meals a day will be provided.
- * Fruits, tea, water, and coffee will be available throughout the day.
- * Participants will have access to common areas such as the living room, spa area, and recreation rooms.
- * Laundry facilities will be available.
- * Internet access will be provided.
- * Shuttle service will be available when needed.



SI Leader Lab 2025 | Comprehensive Funding Available | Virtual Leadership Initiative.

-VidarthiMitra News Desk

The summer school in Europe serves as a professional development opportunity for students, primarily for training purposes. The duration of the funded program is seven days, scheduled from June 21 to June 27, 2025. Additionally, there is no application fee, and an IELTS score is not a requirement for participation in this summer school. Further details regarding the 13th TULIP Summer School in Europe are provided below.

The SI Leader Lab is a leadership initiative provided by the Swedish Institute, aimed at individuals aspiring to become global leaders in an increasingly competitive world. This program represents an exceptional opportunity for emerging leaders, and interested candidates are encouraged to apply without hesitation. Those committed to advancing humanity through the promotion of gender equality, safeguarding civil rights, fostering peace and security, ensuring transparency and accountability, facilitating access to information, and combating corruption are urged to participate in the SI online leadership program.

Young individuals eager to effect positive change are invited to engage with the SI Leader Lab 2025, enhance their knowledge, and share their insights via the online platform established by the Swedish Institute. Participation in the SI Leader Lab will aid in personal development, enhance leadership competencies, support the growth of participants' current organizations, and contribute to the betterment of communities worldwide. This leadership training initiative has been launched by the Government of Sweden to empower young champions of peace and equality.

Advantages of the SI Leadership Program 2025:

Gain professional insights and enhance your understanding of development strategies.

The program allows for the exploration of innovative approaches to advance the organization.

Participants will have the opportunity to exchange knowledge and experiences to address common challenges.

The Swedish Institute Leadership Program will arrange flights to and from Stockholm.

Additionally, participants will receive accommodation and meals in Stockholm during the onsite meeting in Sweden.

TULIP Summer School 2025 in France | Fully Sponsored.

-VidarthiMitra News Desk

The TULIP Summer School 2025 in France is conducted entirely in English, eliminating the necessity for students to learn an additional language. This program is available to master's students, doctoral candidates, and post-doctoral researchers. A total of 25 participants will be selected for this international exchange initiative. The curriculum includes plenary lectures and workshops focused on developing scientific project proposals that bridge various disciplines. The funded summer exchange program encompasses all aspects of interactions among organisms, ranging from molecular interactions to eco-evolutionary dynamics within populations and communities.

Participants in the TULIP Summer School 2025 will engage in collaborative efforts to formulate a team research project proposal across diverse scientific domains. They will have the opportunity to interact with both senior and junior researchers from the research units in Moulis, Toulouse, and Perpignan. This European exchange program presents an exceptional opportunity for participants to forge enduring connections while immersing themselves in an international academic environment and experiencing European culture. The TULIP summer school is a funded short-term exchange initiative that will cover significant expenses associated with the participants' stay in France, including transportation from Toulouse to the summer school venue, full accommodation, meals, and excursions. However, TULIP will not cover travel costs to and from Toulouse.

Through involvement in the UN volunteer initiative, youth have the chance to acquire essential skills, knowledge, and experience, along with the ability to network with other individuals who share similar interests from various parts of the globe. This experience enables them to create a beneficial effect in their local communities and even on a larger scale.



Additionally, UN online volunteering offers exposure and experience in preferred career areas, and participation can be included on resumes to showcase proactivity and dedication. Through engagement in the UN volunteer program, youth can acquire essential experience, abilities, and understanding, while also having the chance to network with individuals who share their interests globally, contributing positively to their communities and farther afield. Additionally, UN online volunteering offers experience and visibility in preferred areas, serving as a notable addition to resumes to reflect proactivity and dedication.

Eligibility Requirements for the TULIP Summer School 2025:

The global summer school invites participants from any nation.

Candidates must be actively pursuing a master's degree in Biology or Ecology, or they may be working on a PhD dissertation (or have finished their PhD recently) or are engaged in post-doctoral studies.

The passports of applicants must remain legitimate until at least October 2025.

An IELTS score is not necessary.

United Nations Online Volunteer Program 2025 UN Volunteer Program Advantages

-VidarthiMitra News Desk

United Nations Online Volunteer Program 2025 is designed to identify talented young individuals globally and guide them towards contributing to peace and sustainable growth. This initiative offers an equal chance for each person to excel and engage in meaningful activities in their lives. Following the global pandemic, through the UN online volunteer initiative, youth across various countries actively participated to mitigate the repercussions of Covid-19 on society. Around 12,000 volunteers have signed up for this program, with 60% hailing from developing nations. Therefore, consider applying for this opportunity to volunteer with the United Nations and be sure to read through to the conclusion.

This online volunteer initiative offers flexibility as it enables you to select a project that aligns with your capabilities. Furthermore, this UN initiative is accessible not only to individuals but also to organizations whose missions resonate with the goals of the United Nations. By engaging in the United Nations online volunteer program, you will have the chance to collaborate and think in a multicultural setting while enhancing your competencies for future endeavors. Additionally, volunteers in this UN online program have the privilege of partnering with esteemed global organizations, providing an opportunity for your efforts to be acknowledged by those entities.

Joining the UN volunteer initiative allows youth to acquire important experience, skills, and knowledge, alongside connecting with other like-minded individuals worldwide, fostering positive changes within their communities and beyond. The UN online volunteering experience can also serve as a valuable addition to resumes, showcasing initiative and dedication while offering insights and exposure in preferred career fields.



- The United Nations offers fully funded volunteer opportunities for 2025 that do not involve any service or application fees.
- The program allows for remote work.
- The tasks assigned can be completed without the need for travel.
- Participants in the 2025 UN volunteer program will have the chance to collaborate with prestigious global organizations, providing an opportunity for their contributions to be acknowledged by these entities.
- A variety of volunteering options are available, enabling individuals to select opportunities that align with their personal interests.



A Comparative Look at Education: India vs. The United States.

-VidarthiMitra News Desk

Education systems are a reflection of a nation's values, priorities, and aspirations for its future. A fascinating comparison can be drawn between the educational landscapes of India and the United States, two diverse democracies with distinct approaches to learning. While both strive to equip their citizens with the knowledge and skills necessary for success, their methods, structures, and philosophies differ significantly.

Structure and Stages:

The foundational structure of schooling sets the stage for a student's educational journey. India, traditionally following a 5+3+3+4 system, is on the cusp of significant change with the New Education Policy (NEP) 2020. This policy aims to revamp the system, potentially leading to a more flexible and holistic structure. In contrast, the United States employs a three-tier system, dividing education into Elementary, Middle, and High School, providing a clear pathway through compulsory education.

Learning Methodologies:

The approach to teaching and learning is where the philosophical differences become apparent. India's system has historically leaned towards rote learning, emphasizing memorization and recall. However, with the advent of NEP 2020, a concerted effort is underway to shift the focus towards critical thinking, problem-solving, and experiential learning.

Subject Flexibility and Choice:

The degree of flexibility in choosing subjects is another key differentiator. While India's system has been historically rigid, limiting students' choices, NEP 2020 promises to introduce greater flexibility. The United States education system is renowned for its high degree of flexibility, allowing students to explore diverse disciplines and tailor their education to their interests and aptitudes. This approach empowers students to pursue their passions and develop a well-rounded education.

Technology Integration and Infrastructure:

In today's digital age, technology plays a crucial role in education. India is making strides in integrating technology into its classrooms, with initiatives like "Digital India" aiming to bridge the digital divide. However, unequal access, particularly in rural areas, remains a significant challenge. The United States, with its advanced technological infrastructure, seamlessly integrates technology into all levels of learning, providing students with access to cutting-edge tools and resources.

Cost and Accessibility:

The cost of education is a major factor influencing accessibility. India offers generally affordable education in its public institutions, making it accessible to a wider population. However, the quality of private education can come at a significant cost.

The Enrollment Hurdle: India's Struggle to Reach Higher Education Targets

-VidarthiMitra News Desk

US vs. Indian educational systems: For many years, there has been a dispute between the US and Indian educational systems. The Indian educational system, which is frequently criticized for being inflexible and unduly reliant on memorization, is said to be falling behind. However, because of its focus on creativity and experiential learning, the US educational system is often seen as superior. But there are problems with both systems. Both nations deal with particular issues, and the cultural and structural distinctions in their educational systems have a significant effect on students. It is important to understand that each has its own set of advantages and disadvantages and that neither is completely superior or worse.

Here's a closer look at the unique characteristics that distinguish the American and Indian educational systems.

The Organization of Education in Schools

There are notable differences between the fundamental educational frameworks in the US and India. With the implementation of the National Education Policy (NEP) 2020, India recently redesigned its educational system. This new framework used a 5+3+3+4 model in place of the conventional 10+2 scheme. Preschool and the early primary grades are included in the foundation stage, which runs from ages three to eight and encourages play-based and activity-centered learning.



Methods of Learning

With pupils having to learn vast amounts of material, India's traditional reliance on memory has frequently come under fire. However, the NEP 2020 aims to move away from memorization and toward a more comprehensive, student-centered approach that places an emphasis on creativity and critical thinking. However, this shift is still in its infancy, and rote learning is still a major problem in many regions of the nation.

Low Outcomes, Limited Potential: India's Education System Needs Reform

-VidarthiMitra News Desk

India, with 20% of the world's youth, has a demographic advantage poised to peak in 2041. However, this potential can only be realized if its youth possess the necessary skills to boost global productivity. A strong education system, especially at the higher education level, is crucial to achieving this. While India has improved access to basic education, significant gaps in higher education must be addressed.

An effective education system is defined by two key elements: widespread access and high enrollment rates across all levels, and quality education reflected in strong learning outcomes.

India has made strides in primary and upper primary education, achieving near-universal enrollment (100.13% GER) at the elementary level (grades 1-8), up from 97.4% in 2011-12. Secondary school transition rates are also improving (88.81%), leading to a 79.56% GER at the secondary level (grades 9-10). However, enrollment significantly drops at higher levels.

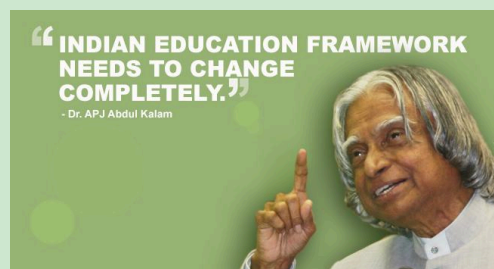

Only 78.41% of students transition to higher secondary education, resulting in a drastically lower GER of 57.76%. GER for higher education.

This is supported by data showing less than 10% of the population holding a graduate degree or higher, while the majority of the workforce has only primary (52.4%) or secondary (37.8%) education. This low attainment in higher education results in a workforce largely confined to low-skill, low-paying jobs, limiting India's potential for high-skilled economic activities.

Drowning in Debt: The Crushing Cost of College in India

-VidarthiMitra News Desk

In Chennai, a 53-year-old business consultant and mother of two began saving for her sons' education years ago when they were in primary school. Despite this foresight, the rising costs of higher education have significantly strained her family's finances. One son is currently studying law at O.P. Jindal Global University, while the other is pursuing a mathematics degree at Krea University. Although the family managed to cover the expenses for their older son's law degree using their savings, they were compelled to sell some of their property to meet the unexpectedly high costs of their younger son's education.

Krea, in addition to the nearly Rs 30 lakh spent on their older son's three-year law degree.

This family's experience is not unique. Across India, parents are struggling to afford the escalating costs of private university education. Faced with yearly increases in tuition and other charges, parents are saving diligently, taking out loans, and even selling assets to finance their children's education at these expensive institutions. They do so with the hope that this significant investment will ultimately pay off in their children's future careers.

How can Indian universities strategically position themselves for significant advancements in the near future?

-VidarthiMitra News Desk

India's massive higher education system, with over 56,000 institutions, 40 million students, and 1.5 million teachers, struggles to meet global benchmarks for access, quality, research, industry ties, and faculty development. The National Education Policy (NEP) 2020 aims to boost enrollment to 50% by 2035 and place Indian universities among the world's top 100.

To realize this vision, India needs to add 26 million student places by 2035, demanding significant investment in personnel, technology, and infrastructure. A 2023 EY-Parthenon-FICCI report recommends prioritizing the initial five-year plan out of the five outlined in a previous 2022 report. Success depends on focusing on quality education, industry relevance, research and innovation, and inclusivity—the cornerstones of India's higher education goals for the next two years.

Over the next 1-3 years, Indian higher education needs to focus on several key areas to improve:

Quality Education: Institutions at all levels, even the top-ranked ones, face challenges across the entire educational process.

Faculty: There's a severe faculty shortage, with even prestigious institutions like IITs and IIMs having significant vacancies. Recruitment and development are crucial.

Digitalization: A lack of clear government policies for technology use in higher education, coupled with limited digital learning integration in weaker institutions, needs to be addressed.

Internationalization: While Indian universities are increasingly looking to establish international campuses, progress has been slow.

Academic Flexibility: Few institutions have adopted the government's academic bank of credits system or offer flexible curriculum and multiple entry/exit points.

Therefore, India's immediate priorities should be: expanding industry-linked PhD programs, creating a dedicated technology policy for higher education, and aligning online courses with national qualification standards.

Connecting with industry is crucial for quality education and ensuring graduates meet industry needs. While top institutions should become industry research and consulting partners, industry investment in Indian higher education, especially in less prestigious institutions, is currently low. With overall graduate employability at just over 50% in 2023, universities must prioritize industry-ready training, career development, and relevant programs.

Therefore, short-term solutions include industry partnerships for work-based learning, establishing centers of excellence, co-developing courses, and hiring industry professionals as professors. Institutions also need career development programs, corporate relations offices, technology transfer cells, and curriculum focused on employability.

Therefore, India's higher education system, while vast, faces significant hurdles in achieving global standards. Inadequate funding, staff shortages, and weak industry ties are just some of the challenges that must be overcome. The National Education Policy 2020 offers a promising roadmap, emphasizing accessibility, equity, and quality. However, realizing the ambitious goals set for 2047 requires more than just long-term vision. It demands a shift towards tangible, short-term targets focused on four key pillars: quality education, industry alignment, research and innovation, and inclusivity. Only through the concerted and collaborative efforts of all stakeholders can India's higher education system truly leap forward, embracing innovation and modernization to prepare its students for the future.

County Community Action Board (CAB) Scholarships Now Open for 2025 Student Applicants

-VidyarthiMitra News Desk

Application deadline is Friday, March 14, 2025 Hillsborough County, Fla. (Feb. 7, 2025) - Hillsborough County students aiming for a higher education have an opportunity to ease their financial burden with a [Community Action Board Scholarship](#) worth up to \$5,000. The scholarship can be used for trade schools, community colleges, or four-year universities. Hillsborough County Community Action Board Scholarships are available to eligible Hillsborough County students wishing to continue their post-secondary education. The scholarships are awarded to students to help alleviate some of the financial burden of tuition so they can focus on furthering their education, not bills.

All applicants must meet the following criteria to be eligible for a 2025 Community Action Board Scholarship:

- Applicants must be between 16 and 24 years old, and have a high school diploma or GED equivalent (16-year-olds may

apply if they are a graduating senior).

- Applicants must reside in Hillsborough County.
- The applicant must have a minimum GPA of 2.0.
- The applicant's household income must fall within 200 percent of the [Federal Poverty Guidelines](#) of the Community Services Block Grant (CSBG).
- Students seeking a master's degree or a second bachelor's degree do not qualify.

Eligibility guidelines are subject to change based on grant requirements.

Applications are due by Friday, March 14, 2025. It is highly recommended that applicants read the full [2025 Community Action Board Scholarship Application Package](#) before applying online, to ensure all documents are complete and requirements are met. A full list of required documents can be found in the application package.

All that you need to know about Post-Matric Scholarship for OBC Students, Tripura 2024-25

-VidyarthiMitra News Desk

Post-Matric Scholarship for OBC Students, Tripura 2024-25 is an initiative of the Ministry of Social Justice and Empowerment, Government of India for OBC category students studying at the post-matriculation level. The scholarship aims to aid students financially so they can pursue higher education. The selected students will receive a monthly maintenance allowance of up to ₹750 and other benefits for the complete duration of the course.

Eligibility:

To be eligible, an applicant must:

- Be an Indian Citizen
- Be a Domicile of Tripura
- Belong to The Other Backward Class (obc) Community (as Notified by The Central or State Government/ut Administration)
- Be Studying Post-Matriculation or Post-Secondary Courses in A Recognised Institution/school/university
- Have an Annual Parent(s)/guardian(s) Income of Not More than ₹1,50,000, Including Their Own Income (if Employed)

The following students are ineligible for the scholarship scheme:

- The scholarships are open to Indian nationals belonging to Other Backward Classes (OBCs) as notified by the Central Government, State Government, or UT Administration.
- These scholarships are awarded for the study of all recognised post-matriculation or post-secondary courses pursued in recognised institutions.
- Applicants must belong to the OBC category as specified for the state/UT where they are permanently settled.
- Applicants must have passed Matriculation, Higher Secondary, or any higher examination from a recognised University or Board of Secondary Education.
- Candidates studying in the same stage of education in different subjects (e.g., I.Sc. after I.A., B.Com. after B.A., or M.A. in one subject after M.A. in another) are not eligible.
- Students who have completed their education in one professional line (e.g., LLB after B.T./B.Ed.) are not eligible.
- Students enrolled in Class 11 of Higher Secondary School or Class 12 of Multipurpose High School are not eligible as it's considered a continuous school course. However, students who pass the

- tenth class of these courses (considered equivalent to Matriculation) and then join other courses are eligible as post-matric students.
- Students pursuing postgraduate medical courses are only eligible if they are not allowed to practice during their studies.
- Students who join recognized professional or technical certificate/diploma/degree courses after failing or passing undergraduate/postgraduate examinations in Arts/Science/Commerce are eligible for scholarships if they meet other requirements. Subsequent failures are not condoned except for courses in Group 'A', and no further course changes are allowed after receiving the scholarship.
- Students pursuing courses through correspondence (including distance and continuing education) are eligible for reimbursement of non-refundable fees. Additionally, they are eligible for an annual allowance of ₹900 for essential/prescribed books.

Benefits for Selected Candidates:

Maintenance Allowance (Group A)

- Courses: Degree, postgraduate, M.Phil, PhD, Post-Doctoral research in specialized fields like Medicine, Engineering, Architecture, Management, etc.
- Special Provision: ₹5,000 per flying hour (maximum 200 hours) for Commercial Pilot License courses (20 slots annually).
- Hostellers: ₹750/month
- Day Scholars: ₹350/month

Group B

- Courses: Graduate/postgraduate programs in fields like Pharmacy, Nursing, LLB, Mass Communication, Hospitality, Interior Decoration, etc.
- Hostellers: ₹510/month
- Day Scholars: ₹335/month

Group C

- Courses: General graduate degrees (e.g., BA, B.Sc., B.Com) not covered in Groups A and B.
- Hostellers: ₹400/month
- Day Scholars: ₹210/month

Group D

- Courses: Post-matriculation non-degree courses like senior secondary (Class XI/ XII), ITI, and 3-year diploma programs.
- Hostellers: ₹260/month
- Day Scholars: ₹160/month
- Note: Scholars entitled to free boarding/lodging will receive 1/3rd of the hostellers' rate.

Dr. BR Ambedkar Scholarship for Topper Award, Delhi 2025

-VidyarthiMitra News Desk

About The Program

Dr. BR Ambedkar Scholarship for Topper Award, Delhi 2024-25 is an opportunity offered by the Department for the Welfare of SC/ST, Government of NCT of Delhi, for topper students belonging to SC/ST/OBC category studying in the technical/professional course. The selected meritorious students will be awarded ₹25,000 for each discipline after completion of the degree course in the university.

To be eligible, an applicant must:-

- be an Indian citizen
- be a domicile of Delhi
- belong to the Scheduled Caste (SC)/ Scheduled Tribe (ST)/Other Backward Class (OBC) community
- have passed Class 10 and 12 from a recognised institution located in Delhi
- be studying a professional/technical degree course at an institute in Delhi
- have achieved top marks in the final year exams of the respective studies

Benefits

The selected candidates will receive an award of ₹25,000.

Documents

- Caste certificate (SC/ST/OBC) issued by the competent authority of Delhi

Sanskriti Foundation scholarships for international students, 2025-26

-VidyarthiMitra News Desk

International scholarships, fellowships or grants are offered to students outside the country where the university is located. These are also called as financial aid and many times the financial aid office of the Sanskriti Foundation deals with it. Sanskriti Foundation scholarships are offered by Sanskriti Foundation to study or research there.

There are various Sanskriti Foundation scholarships for international students. Apart from the university-based scholarships, there are many other organizations including foundations, trusts, corporates etc. Who offer scholarships for international students. To help, we list out the latest international scholarships, fellowships and grants information. The Sanskriti Foundation scholarships application form is also available to apply online for the scholarships.

Quick links for Sanskriti Foundation scholarships:

- Sanskriti Foundation [Bachelors scholarships](#) (also known as Sanskriti Foundation undergraduate scholarships)
- Sanskriti Foundation [Masters scholarships](#)
- Sanskriti Foundation [PhD scholarships](#)

Below is the list of top 5 Sanskriti Foundation scholarships for International students:

Sanskriti - Prabha Dutt Fellowship 2025

Sanskriti - Prabha Dutt Fellowship 2025 is a Partial Funding international scholarship offered by the [Sanskriti Foundation](#) for international students. Students eligible for this scholarship are: Open to Indian national. This scholarship can be taken for pursuing in Journalism. 10 Mar, 2025 is the deadline to send applications for Sanskriti - Prabha Dutt Fellowship 2025. The value of the scholarship is Rs. 1,00,000 + travel expenses. This scholarship can be taken at Institutions/Organisation in India .

Sanskriti Foundation's Kalakriti Fellowship for Indian Classical Dance in India, 2025

Sanskriti Foundation's Kalakriti Fellowship for Indian Classical Dance in India, 2025 is a Partial Funding international scholarship offered by the [Sanskriti Foundation](#) for international students. Students eligible for this scholarship are: Open to Indian citizens. This scholarship can be taken for pursuing in Indian classical dance. 10 Mar, 2025 is the

the competent authority of Delhi

- Certificate/diploma/degree/marksheet for all previous qualifying examinations

How can you apply?

Eligible candidates can apply for the scholarship through the following steps:-

Step 1: Click on the 'Apply Now' button. Step 2: Click on the 'Register' button and fill in the required details to register (Note:- If already registered, log in using Gmail/Mobile number/Email ID).

Step 3: Navigate to 'Apply Services' and click on it.

Step 4: Now, click on the 'Register' button, select the Aadhaar card for the document type, enter the Aadhaar number and captcha code.

Step 5: Tick the checkbox and click on the 'Continue' button to register.

Step 6: After successful registration, log in using the credentials (user ID, password, and captch code).

Step 7: Select the scholarship scheme and fill the relevant details.

Step 8: Upload the required documents in the prescribed format and click on the 'Submit' button.

Important Dates

Application deadline: 31st May 2025

deadline to send applications for Sanskriti Foundation's Kalakriti Fellowship for Indian Classical Dance in India, 2025. The value of the scholarship is Rs. 50,000 given in two installments. This scholarship can be taken at Institutions in India. Deadline to send applications for Sanskriti Foundation's Kalakriti Fellowship for Indian Classical Dance in India, 2025. The value of the scholarship is Rs. 50,000 given in two installments. This scholarship can be taken at Institutions in India.

Sanskriti - Geddes Scholarship 2025

Sanskriti - Geddes Scholarship 2025 is a Partial Funding international scholarship offered by the [Sanskriti Foundation](#) for international students. Students eligible for this scholarship are: Open to Indian nationals. This scholarship can be taken for pursuing in Planning and Architecture. 10 Mar, 2025 is the deadline to send applications for Sanskriti - Geddes Scholarship 2025. The value of the scholarship is INR 45,000/-. This scholarship can be taken at Universities/Colleges in India.

Sanskriti - Mani Mann Fellowship 2025

Sanskriti - Mani Mann Fellowship 2025 is a Partial Funding international scholarship offered by the [Sanskriti Foundation](#) for international students. Students eligible for this scholarship are: Open to Indian nationals. This scholarship can be taken for pursuing in Music, Hindustani Classical Music. 10 Mar, 2025 is the deadline to send applications for Sanskriti - Mani Mann Fellowship 2025. The value of the scholarship is Rs.100,000 given in two phases. This scholarship can be taken at Institutions in India.

Sanskriti - Madhobi Chatterji Memorial Fellowships in India, 2024

Sanskriti - Madhobi Chatterji Memorial Fellowships in India, 2024 is a Partial Funding international scholarship offered by the [Sanskriti Foundation](#) for international students. Students eligible for this scholarship are: Open to Indian citizens. This scholarship can be taken for pursuing in Indian classical music and dance. 10 Mar, 2025 is the deadline to send applications for Sanskriti - Madhobi Chatterji Memorial Fellowships in India, 2024. The value of the scholarship is Rs.1,00,000 given in two installments. This scholarship can be taken at India .

Tata Capital Pankh Scholarship Program 2024-25

-VidarthiMitra News Desk

The Tata Capital Pankh Scholarship Program 2024-25 is an initiative of Tata Capital Limited to support the higher education of students belonging to economically weaker sections of society. Under this scholarship program, students studying in Classes 11 and 12 or pursuing general graduation/diploma/polytechnic courses will be provided with a one-time scholarship of up to 80% of their course fees or an amount ranging from INR 10,000 to INR 12,000 (whichever is less) to fulfill their academic dreams.

About Tata Capital Limited

Tata Capital Limited, a leading financial services company within the Tata Group, has introduced this scholarship program as a part of its Corporate Social Responsibility (CSR) efforts. It aims to positively impact society by providing educational support to deserving and underprivileged students. Alongside this scholarship, Tata Capital actively engages in

various CSR initiatives focused on Education, Skill Development, Environment, and Health, striving to make a meaningful difference in these areas.

- Tata Capital Pankh Scholarship Program for Class 11 and 12 Students 2024-25
- Eligibility/Deadline Date: 15-Feb-2025
- Students studying in Class 11 or Class 12 at a recognised educational institution in India can apply.
- Applicants must have scored at least 60% marks in the preceding class.
- The annual family income of the applicants from all sources must be less than or equal to INR 2.5 lakh.
- Children of employees of Tata Capital & Buddy4Study are not eligible.
- Open to Indian nationals only.

Benefits:

- Up to 80% of course fees paid by the student or up to INR 10,000 (whichever is less)

ISC2 Graduate Scholarships

-VidarthiMitra News Desk

APPLICATIONS OPEN IN JANUARY 15, 2025 AND CLOSE MARCH 3, 2025 AT 11:59 PM EST

Award/No Award notifications for school year 2025-2026 will be emailed June 2025

AWARDS

- Up to 20 scholarships will be awarded. Each scholarship award will be between \$1,000 – \$5,000 USD.
- If awarded: the funds will be sent to the school with instructions that it be applied to tuition, fees, books, and required materials. Recipients do NOT receive award funds.
- Awards must be accepted within three (3) weeks of award notification. If the award has not been accepted it will be awarded to another applicant.
- All awards must be disbursed to the recipient's educational institution by Dec. 31st of the award year. Awards will NOT carry over to the following year.
- Awards do not renew. You will need to reapply each year in order to be considered for another award.

ELIGIBILITY

- Must be pursuing, or plan to pursue, a degree with a focus on cybersecurity or information assurance in the fall of 2025.
- Must be pursuing a Master's Degree program or doctoral studies. If you are, or will be, pursuing a bachelor degree please apply for the [ISC2 Undergraduate Scholarship](#).
- GPA must be at least 3.5 on a 4.0 scale (or an analogous rank based on a comparable scale)
- Note: If you have just been accepted to Graduate School, or are just beginning classes, you will use the final cumulative GPA from your undergraduate degree transcript to meet this criteria.
- If you need to convert your GPA please visit <https://applications.wes.org/igpa-calculator/>
- You may be a citizen of any country (US citizenship not required)
- May be attending on campus or online
- May be attending full time or part time
- May be attending in the US or Internationally
- You do not currently need to be enrolled, however no awards will be disbursed until the recipient is enrolled in a college or university.

WHAT YOU WILL NEED

1. Unofficial transcripts from your current (or most recent) educational institution. If awarded; no funds will be disbursed until official

transcripts have been received. Please do NOT mail hard copies of transcripts.

2. One Letter of Recommendation outlining the following:

- How long have you known the applicant and in what capacity?
- What skills or abilities does the applicant have that will support him/her in completing a degree?
- What other information about the applicant should be taken into consideration?
- NOTE: Academic references are preferred; however, you may submit a professional letter of reference addressing the points above.

3. Resume/CV – No more than 3 pages maximum. Do not include links to publications.

4. Essay questions to be filled out in application. Maximum word count is 250 per question:

- Tell us why you should be chosen to receive this ISC2 Cybersecurity Scholarship and what makes you stand out from your peers?
- Describe why you need the scholarship.
- Describe your personal and education backgrounds.
- Describe why you chose your major and your goals for your academic career. What makes you a candidate for success in information security and what are your goals for your professional career.
- Describe any contributions to the cybersecurity field i.e., volunteer work, articles, etc., and any other hobbies or extracurricular activities and what they mean to you. (Do not include links to articles)
- Please tell us anything else you would like us to know about you.

SCORING CRITERIA

Applicants will be scored by members of ISC2 and scholarship sponsors (if applicable). Scoring will be based upon three categories:

- Passion
- Merit
- Financial Need

NOTE: Not all applicants will receive a scholarship. Scholarships are a one-time award and must be re-applied for each year in order to be considered for another scholarship. No scholarship awards will be paid until July 2025.

Vyasakabi Fakir Mohan Bhasabrupti Scholarship

-VidarthiMitra News Desk

The scheme "Vyasakabi Fakir Mohan Bhasabrupti Scholarship" is a Scholarship Scheme by the Higher Education Department, Government of Odisha. The objective of the scheme is the promotion of Odia Language by way of encouraging meritorious students to take up higher studies in Odia Language at U.G. and P.G. level. This is one time scholarship of ₹ 20,000/- per student. There are 1500 scholarships awarded every year out of which 1200 are for the "Students studying UG with Odia Honours" Category, and 300 are for the "Students studying PG in Odia" Category.

Benefits

This is a one-time scholarship of ₹ 20,000/- per student.

There are 1500 scholarships awarded every year out of which 1200 are for the "Students studying UG with Odia Honours" Category, and 300 are for the "Students studying PG in Odia" Category.

A student availing of other scholarships is also eligible for this Bhasabrupti.

Eligibility

Students who have been admitted in +3 Arts with Odia as Honours subject (1St Year) in Degree Colleges / Autonomous Colleges/ State Universities of Odisha or other states after passing +2 Examination with 60% marks aggregate

JK Tyre Shiksha Sarthi Scholarship 2024-25 Application Ongoing!

-VidarthiMitra News Desk

The JK Tyre Shiksha Sarthi Scholarship 2024-25 is an initiative by JK Tyre to support the education of daughters of heavy motor vehicle drivers in Tamil Nadu and Karnataka. The application process is currently open and will continue until February 15, 2025.

Eligibility Criteria:

- Gender: Female students only.
- Parent's Occupation: Daughter of a heavy motor vehicle driver.
- Family Income: Annual family income should be less than ₹5 lakhs.
- Residency: Residents of Tamil Nadu or Karnataka.
- Course Enrollment: Pursuing one of the following courses:
 - Undergraduate programs.
 - Specialized courses.
 - ITI courses.
 - Diploma courses.
 - B.Sc Nursing.
 - B.E/B.Tech.

Application Process:

conducted by CHSE, Odisha will be eligible for applying for this Scholarship at U.G. level.

The students who have taken admitted to M.A. (Odia) in any of the State Universities/ Degree Colleges and Autonomous Colleges in Odisha after securing 60% marks in Odia Honours subject will also be eligible for this Scholarship at the P.G. level.

A student availing of other scholarships is also eligible for this Bhasabrupti.

1. The students will be selected on the basis of marks secured in the qualifying examination, i.e., students pursuing +3 Arts having Odia as an Honours subject will be selected on the basis of their overall marks in the +2 examination conducted by CHSE, Odisha.
2. The students pursuing M.A. (Odia) will be selected on the basis of the marks secured in Odia Honours in the +3 Arts final examinations. Basing on the common merit list for both categories the targeted beneficiaries will be selected (if the number of eligible applicants is more than the target).

NOTE: Students pursuing their higher studies through distance learning/ correspondence courses are not eligible for such scholarships.

The JK Tyre Shiksha Sarthi Scholarship 2024-25 is an initiative by JK Tyre to support the education of daughters of heavy motor vehicle drivers in Tamil Nadu and Karnataka. The application process is currently open and will continue until February 15, 2025.

Eligibility Criteria:

- Gender: Female students only.
- Parent's Occupation: Daughter of a heavy motor vehicle driver.
- Family Income: Annual family income should be less than ₹5 lakhs.
- Residency: Residents of Tamil Nadu or Karnataka.
- Course Enrollment: Pursuing one of the following courses:
 - Undergraduate programs.
 - Specialized courses.
 - ITI courses.
 - Diploma courses.
 - B.Sc Nursing.
 - B.E/B.Tech.

Application Process:

1. Visit the official Vidyasaarathi portal: <https://www.vidyasaarathi.co.in/>.
2. Register as a new user or log in if already registered.
3. Search for the 'JK Tyre Shiksha Sarthi Scholarship' under the available schemes.
4. Fill in the application form with the required personal and academic details.
5. Upload necessary documents, including proof of father's occupation, income certificate, and academic records.
6. Submit the application before the deadline on February 15, 2025.

Scholarship Amount:

The scholarship amount varies depending on the course of study. Specific details regarding the financial assistance provided for each course are available on the official Vidyasaarathi portal.

This scholarship aims to promote higher education among female students by alleviating financial constraints, thereby empowering them to achieve their academic and career aspirations.

The Centrally Sponsored Post-Matric Scholarship Scheme for ST Students in Ladakh

-VidarthiMitra News Desk

It is an initiative by the Government of India to support Scheduled Tribe (ST) students pursuing post-matriculation studies.

Key Details:

Eligibility Criteria:

- Indian citizen and domicile of Ladakh.
- Belong to the Scheduled Tribe (ST) community.
- Enrolled in post-matriculation studies at recognized institutions.
- Annual family income not exceeding ₹2,00,000.
- Not availing benefits under any other scholarship or stipend.

Benefits:

- Maintenance allowance up to ₹1,200 per month.
- Additional allowances for books, ad-hoc grants, and other benefits.

Application Process:

Applications are submitted online through the National Scholarship Portal (NSP).

Required documents include a passport-size photograph, academic certificates, caste certificate, annual family income certificate, and previous scholarship receipt (if applicable).





Labour Ministry inks pact with FoundIt, to bring 10 lakh more jobs on National Career Service portal annually

-VidyarthiMitra News Desk

The Ministry of Labour & Employment has signed an agreement with FoundIt, a leading job portal, to expand job opportunities for young job seekers in India. Under this partnership, an additional 10 lakh job openings will be added to the National Career Service (NCS) portal every year.

Union Labour Minister Mansukh Mandaviya emphasized how the NCS portal plays a key role in connecting job seekers with employment opportunities, both in India and abroad. The portal currently registers between 3,000 to 4,000 new job postings daily and is expected to bring in 1.25 lakh international vacancies and over 10 lakh domestic vacancies each year. With over 40 lakh employers onboard, the NCS portal has already facilitated more than 4.40 crore job listings since its launch. At any given time, around 10 lakh job openings are available, offering a steady stream of opportunities for Indian youth.

To further expand global job prospects, the NCS portal has been integrated with the e-Migrate platform, which includes over 500 registered recruitment agencies under the Ministry of External Affairs. The government is encouraging young people to register on the platform to access a wide range of career opportunities. Labour Secretary Sumita Dawra noted that countries like Germany, Finland, and various Middle Eastern nations are actively looking for skilled workers across different industries. Through this partnership, NCS will help facilitate these international job opportunities for Indian job seekers. V. Suresh, CEO of FoundIt, praised the initiative, stating that it aligns with the government's vision of 'Sabka Saath, Sabka Vikas' by ensuring more inclusive job opportunities. He highlighted



that employment is a key driver of economic growth and that the government's focus on career development is reflected in the growing success of the NCS portal.

This agreement will give job seekers on the NCS portal access to openings not only in India but also in Southeast Asia and the Middle East. FoundIt will collect job postings from employers in these regions across both formal and informal sectors.

The job listings will be integrated into the NCS portal through APIs for seamless access. Additionally, the partnership will focus on connecting diverse candidates, including women and persons with disabilities, to suitable job opportunities.

To make the process more efficient, the Ministry of Labour & Employment will facilitate database integration, enabling FoundIt to connect with a broader talent pool through an easy-to-use technology interface, accessible both online and offline.

This collaboration marks another step in the government's efforts to bridge the gap between job seekers and employers, improving access to career opportunities for millions of Indians.

AI to impact repetitive jobs, generate large scale employment from FY27: IT industry leader

-VidyarthiMitra News Desk

Artificial Intelligence (AI) is poised to significantly influence the job market in the coming years. While AI is expected to automate many repetitive tasks, leading to the displacement of certain roles, it is also anticipated to create a substantial number of new employment opportunities. According to a study by ServiceNow, India will need to upskill or reskill 16.2 million workers in AI and automation to meet the country's skill deficit. Additionally, the study predicts that 4.7 million new jobs in the technology sector will be created by 2027.

The manufacturing sector is expected to experience the most significant disruption, with 23% of its workforce primed for automation and skill augmentation.

Other sectors likely to be affected include agriculture, forestry, fishing (22%), wholesale and retail trade (11.6%), transportation and storage (8%), and construction (7.8%).

In Hyderabad, industry experts estimate that out of approximately 905,000 IT employees, 15-20% of jobs could be eliminated by some form of generative AI. However, they also anticipate that more jobs will be generated due to automation. For every 2-3 jobs that may be lost, 4-5 new jobs are expected to emerge in AI and machine learning segments. This underscores the importance of skilling, upskilling, and reskilling in emerging technologies to seize these new opportunities.

He recognized the concerns surrounding potential job losses attributed to emerging technologies but asserted that these challenges can be addressed through effective skilling and upskilling programs.

Government officials also emphasize the need for workforce adaptation. Telangana's IT and Industries Minister, D. Sridhar Babu, highlighted the importance of integrating AI in governance to enhance productivity and lead technology to the next level. He acknowledged the fear of job losses due to new technology but stressed that this can be mitigated through skilling and upskilling initiatives.

In summary, while AI is expected to automate certain tasks and potentially displace some jobs, it also presents significant opportunities for job creation. The key to leveraging these opportunities lies in proactive upskilling and reskilling of the workforce to align with the evolving demands of the job market.



Top 5 HR trends to embrace for a future-ready workforce in 2025

-VidyarthiMitra News Desk

In 2025, Human Resources (HR) leaders are focusing on several key trends to prepare their organizations for the future. These trends aim to enhance efficiency, embrace technological advancements, and leverage workforce.

1. Maximizing Impact with Value Engineering
HR departments are adopting value engineering principles to design programs that optimize costs while delivering sustainable results. This approach shifts the focus from traditional Return on Investment (ROI) metrics to a broader Return on Value (ROV) framework. By reducing waste and improving efficiency across talent programs, HR initiatives can directly contribute to business growth and employee engagement.

2. AI Transforming Workflows
Artificial Intelligence (AI) is reshaping industries, and organizations are moving beyond merely adding AI to existing processes. The emphasis is on reimagining workflows by redesigning jobs, team structures, and decision-making processes to fully leverage AI's potential. Businesses are prioritizing advanced skills such as identifying automation opportunities and enhancing efficiency. Investments are shifting toward specialized AI tools tailored to specific business needs, ensuring true transformation rather than incremental improvements.

3. Skills Inventories Driving Agility
Maintaining a comprehensive skills inventory is becoming crucial for workforce agility. HR leaders are quantifying the supply and demand of key skills and aligning them with business

goals. In the long term, organizations aim to integrate human capital metrics into broader business valuation frameworks, positioning workforce skills as tangible assets. Leveraging real-time skills data ensures that the right talent is in the right place at the right time.

4. Leveraging Generational Diversity
With a workforce spanning multiple generations, organizations are fostering collaboration across age groups. By embracing diverse perspectives, businesses can enhance problem-solving, innovation, and adaptability. Building an inclusive culture where all generations feel valued leads to increased engagement, productivity, and long-term retention.

By embracing these trends, HR leaders can drive meaningful change, ensuring their organizations remain competitive in an increasingly dynamic and AI-driven world.



Infosys hiring: 'Power' programme for campus placements; Rs 9 lakh salary on offer for freshers

-VidyarthiMitra News Desk

In a strategic move to attract top-tier talent, Infosys has unveiled its 'Power' programme, a new initiative within its campus placement strategy. This programme is designed to offer fresh graduates significantly higher salary packages, reaching up to ₹9 lakh per annum, a notable increase from the company's traditional entry-level packages of ₹3-3.5 lakh.

Focus on Specialized Skills

The 'Power' programme is tailored to identify and recruit candidates with specialized skills in areas such as coding, software development, and programming. The selection process emphasizes rigorous assessments, including coding challenges and software problem-solving tasks, to evaluate the proficiency of applicants in these critical domains.

Industry Context and Comparisons

This initiative aligns Infosys with current industry trends, where leading IT firms are enhancing their recruitment strategies to secure specialized talent. For instance, Tata Consultancy Services (TCS) has implemented a 'Prime' programme, offering freshers salaries between ₹9-11 lakh per annum for software development roles. TCS has further expanded this programme to encompass emerging technologies such as artificial intelligence (AI), generative AI (GenAI), and machine learning (ML).

Recruitment Plans Amid Industry Dynamics

Despite a recent slowdown in the technology services sector, Infosys is proactively planning to recruit between 15,000 and 20,000 graduates in the fiscal year 2025. This approach reflects the company's commitment to investing in fresh talent to drive innovation and meet evolving client demands. Similarly, TCS aims to hire approximately 40,000 freshers, maintaining its recruitment levels from the previous year.

Adapting to Market Conditions

The broader IT industry has experienced a period of adjustment, with leading companies reducing their headcounts by over 70,000 employees during fiscal 2024 due to a slowdown in business.

TCS currently employs fresh graduates across three distinct categories: 'Ninja' with compensation approximately Rs 3.6 lakh, 'Digital' at Rs 7.5 lakh, and 'Prime'.

In response to the rising demand for expertise in cloud computing, AI/ML, and cybersecurity, both Infosys and TCS have intensified their efforts to recruit specialized talent, spurred by ongoing digital transformation initiatives.

Despite a challenging macroeconomic landscape, Infosys intends to hire between 15,000 and 20,000 graduates in FY25, while TCS plans to onboard 40,000 freshers, thereby sustaining the recruitment levels of the previous year.

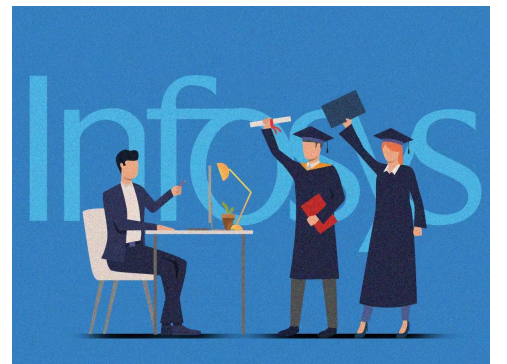

1. A car falls off a ledge and drops to the ground in 0.7 s (let $g=10\text{ms}^{-2}$)

What is its speed on striking the ground?

1. 7 ms⁻¹
2. 8 ms⁻¹
3. 4 ms⁻¹
4. 7 ms⁻¹

2 In an electric circuit, Rheostat is often used to change the _____ in the circuit.

1. temperature
2. resistance
3. electric current
4. potential difference

3 Aamir Khan was honoured with the Best Actor Award in 2017 at:

1. National Film Awards
2. IIFA Awards
3. Indian Film Festival
4. Filmfare Awards

4 Which tissue is responsible for transport of materials away from the root?

1. Ground tissue
2. Cambium
3. Phloem
4. Xylem

5 On which day is 'World Hindi Day' (WHD) observed every year to mark the first anniversary of World Hindi Conference (WHC), which was held in 1975?

1. 5th September
2. 14th October
3. 10th January
4. 26th January

6 ₹ 1,080 invested for 3 months gave an interest of ₹27. The simple rate of interest per annum was:

1. 2.5%
2. 5%
3. 7.5%
4. 10%

7 Given below is a statement followed by two assumptions numbered I and II. You have to consider the statement and the following assumptions and decide which of the assumptions is implicit in the statement.

Statement: "Mandarin Oriental hotel has yet another new fan, Amitabh Bachchan," reads a hotel advertisement.

Assumptions:

- I. Mandarin Oriental is an expensive hotel.
- II. Mandarin Oriental is owned by Amitabh Bachchan.

1. Only assumption I is implicit
2. Both I and II are implicit.
3. Neither I nor II is implicit
4. Only assumption II is implicit

8 P 3 R I M J 3 Q % W @ / N S E 5 X Y 1 # 8 0

In the above series, the 6th term to the left of the 15th term from the left is:

1. W
2. %
3. 8
4. #

9 If the edge of a cube is halved, then its volume reduces to _____ times the actual volume.

1. 1/3
2. 1/4
3. 1/8
4. 1/2

10 The time period of a vibrating body is 0.04s, then the frequency of the wave is _____.

- Ans
- 25Hz
 - 20Hz
 - 250Hz
 - 200Hz

11 In the Modern Periodic Table, there is an anomaly when it comes to the position of _____ because it can be placed either in group 1 or group 17 in the first period.

- a. He
- b. H
- c. Li
- d. Be

12 What is the scientific term for the speed of an object moving in a definite direction?

- a. Time
- b. Acceleration
- c. Velocity
- d. Motion

13 Who has been appointed as the Executive Director of Canara Bank?

- a. Ravi Venkatesan
- b. Murali Ramaswami
- c. Mahesh Kumar Jain
- d. Debashish Mukherjee

14 The sample space of four coins tossed together is:

- a. 8
- b. 64
- c. 32
- d. 16

15 Two pipes, A and B, can fill a tank in X minutes and 6 minutes, respectively. If both the pipes are used together, then they take 1.5 minutes to fill the tank. Find the value of X.

- a. 1 min
- b. 4 min
- c. 5 min
- d. 2 min
- e.

General Awareness & General Knowledge Questions

1. In Computers, what does ALU stand for?

- (1) Advanced Logic Unit
- (2) Accelerated Logic Unit
- (3) Arithmetic Logic Unit
- (4) Asymmetric Logic Unit

2. The ratio of ages of Suraj and Mohan 4 years ago was 7 : 8, and after 5 years, their ratio will become 10 : 11. Find the present age of Suraj.

- (1) 24 years
- (2) 25 years
- (3) 28 years
- (4) 21 years

3. Select the related word from the given alternative.

ROAD : URDG :: LANE : ?

- (1) ODQH
- (2) MDQH
- (3) QHDN
- (4) QNDH

4. The book titled 'Social Harmony' is written by:

- (1) Atal Bihari Vajpayee
- (2) Shyama Prasad Mukherjee
- (3) Narendra Modi
- (4) Lal Krishna Advani

5. BJP had won how many seats in the Lok Sabha election 2019?

- (1) 320
- (2) 350
- (3) 303
- (4) 280

Netaji Subhas Chandra Bose Military Schools (NSCBMS) – Overview

Netaji Subhas Chandra Bose Military Schools (formerly known as Rashtriya Military Schools) are premier institutions run by the Ministry of Defence, Government of India. These schools aim to provide quality education along with military training to prepare students for careers in the armed forces.

Key Features:

- Affiliation: Central Board of Secondary Education (CBSE)
- Classes: VI to XII (admission primarily in Class VI and IX)
- Medium of Instruction: English
- Eligibility: Boys only (girls may be allowed in the future)
- Selection Criteria: Entrance Exam + Physical & Medical Test
- Training Focus: Academic excellence, discipline, physical fitness, leadership skills

1. Mathematics (Numerical Ability & Arithmetic)

1. A box contains 5 red balls, 3 blue balls, and 2 green balls. What is the total number of balls?
2. The sum of angles in a triangle is always ?
3. Convert 0.75 into a fraction.
4. Find the HCF of 24 and 36.
5. A rectangle has a length of 12 cm and a breadth of 8 cm. Find its perimeter.
6. A father is 30 years older than his son. If the son is 15 years old, how old is the father?
7. Solve: $(15 \times 5) \div 3 + 12$.
8. If the area of a square is 49 cm^2 , what is the length of its side?
9. Find the missing number in the pattern: 4, 8, 16, 32, ?
10. A shopkeeper bought 10 pens for ₹150 and sold them for ₹180. What is his profit per pen?

2. English (Grammar, Vocabulary, and Comprehension)

(A) Grammar-Based Questions

1. Identify the verb in the sentence: "The birds are flying in the sky."
2. Fill in the blank: She ___ playing in the park. (is/are/was)
3. Choose the correct article: Ramesh is ___ honest man. (a/an/the)
4. Convert to past tense: "She writes a letter every day."
5. Choose the correct preposition: "The book is ___ the table." (in/on/under)

(B) Sentence Correction & Rearrangement

1. Rearrange the words to form a meaningful sentence: is / my / favorite / blue / color.
2. Correct the sentence: She go to school daily.
3. Fill in the blank with the correct conjunction: I wanted to go outside, ___ it was raining. (but/and/or)
4. Convert into passive voice: "The teacher teaches the students."
5. Find the opposite word of "polite".

3. General Knowledge (Current Affairs & Static GK)

1. Who is the current Prime Minister of India?
2. What is the capital of Madhya Pradesh?
3. What is the national animal of India?
4. Who wrote the Indian National Anthem?
5. In which year did India become independent?
6. What is the full form of NASA?
7. Which river is known as the "Ganga of the South"?
8. What is the currency of Japan?
9. Which sport is Virat Kohli associated with?
10. What is the longest river in India?

4. Intelligence Test (Reasoning Ability & Logical Thinking)

(A) Number Series & Patterns

1. Find the missing number in the sequence: 3, 6, 9, ?, 15
2. What comes next in the pattern? 2, 5, 10, 17, ?
3. If A = 1, B = 2, C = 3, what is the numerical value of the word "DOG"?
4. Find the odd one out: Rose, Jasmine, Mango, Lily
5. If $5 + 3 = 28$, $6 + 4 = 40$, then what is $7 + 2 = ?$

(B) Logical Puzzles

1. Rahul is taller than Ramesh but shorter than Suresh. Who is the shortest?
2. A clock shows 4:45 PM. What is the angle between the hour and minute hands?
3. If "TREE" is coded as 5733, how will "LEAF" be coded?
4. A boy is facing North, turns 90° left, then 180° right. Which direction is he facing now?
5. If a man walks 3 km East, then 4 km North, how far is he from the starting point?

5. Physical Fitness & Endurance Test (After Written Exam)

1. Running Test: Complete a 1600-meter run in the given time limit.
2. Push-Ups: Perform at least 10 push-ups in a single attempt.
3. Sit-Ups: Complete 15 sit-ups continuously.
4. Jumping Test: Perform a minimum height jump in high jump or long jump.
5. Medical Examination: Pass the basic medical fitness test (eye vision, height, weight check).

Extra Practice Questions for Advanced Preparation

(A) Mathematics (Word Problems & Logical Thinking)

1. A car travels at 60 km/hr for 3 hours. How far does it go?
2. A bottle holds 1.5 liters of water. How many milliliters is that?
3. A school has 25 classrooms. Each classroom has 40 students. How many students are there in total?
4. A boy bought 5 chocolates for ₹20. What is the cost of 8 chocolates?
5. If a train departs at 10:15 AM and reaches its destination at 2:45 PM, how long is the journey?

(B) English (Vocabulary & Word Usage)

1. Find the synonym of "Happy".
2. What is the opposite of "Cold"?
3. Fill in the blank: The sun rises ___ the east. (on/in/from)
4. Choose the correct spelling: A. Beleive B. Believe C. Belive
5. Find the correct word: The ___ of India is Narendra Modi. (President/Prime Minister)

Preparation Tips

Daily Practice: Solve sample papers regularly.

English & Vocabulary: Read books, newspapers, and practice grammar rules.

GK & Current Affairs: Stay updated with the latest news.

Reasoning Puzzles: Practice number patterns, coding-decoding, and logical puzzles.

Physical Fitness: Run daily, do push-ups, and maintain stamina.

10 ADVERTISEMENTS (COURTESY VARIOUS NEWSPAPERS)

16 February 2025, Sunday

Organised by IDEMI Mumbai Ministry MSME Govt. of India
Government Certificate Course on Artificial Intelligence with Medical Practices

Course Duration: 4 Days
 Timing: 1.30 pm - 5.00 pm
(ONLINE)
 Course Date: 15, 16, 22, 23 February 2025

mail ID: training@idemi.org Website: www.idemi.org Ph: (022) 2405 0301/2/3

Topics: AI in clinical decision support, AI in predictive analytics and personalised medicine, Implementing AI in healthcare settings, Future trends & innovating in AI for Medicine.

Course Fees- 4000+ 18% GST
 After successful completion certificate will be issued.

Call for details between 10 am to 6 pm
 Contact-9403566219, 8007765693, 8275181503, 9869087617

New Edition
Pariksha Pe Charcha 2025
 New Format

To beat exam stress!
 PM Modi's candid conversation with students
 Expert advice to ace exams • A lively, engaging format

LIVE ON
10th FEB | 11:00 AM

Registration window opens-January 20, 2025
 Registration window closes-February 25, 2025
 Entrance Test- March 2, 2025
 Online classes will start from March 27, 2025

More details about the program can be found on the website: <https://cscl.iitb.ac.in>
 Contact- 0731-6603333-5593 Email id: office-cscl@iitb.ac.in

INDIAN INSTITUTE OF TECHNOLOGY INDORE AND NATIONAL LAW INSTITUTE UNIVERSITY BHOPAL
 Jointly offer a two-year degree program

MASTER OF SCIENCE IN CYBER SECURITY AND CYBER LAW (ONLINE MODE)

ELIGIBILITY
 Qualifying Degree
 First-class degree (as defined by the awarding Institute/ University with 5% relaxation for the SC/ ST/ PwD category) in
 • B.Tech/ B.E. (Any Branch) OR Four years BS/B.Sc. (Honours)/BCA (Honours) or M.Sc. in Computer Science /Statistics/ MCA/ MBA or an equivalent degree with at least two courses in Mathematics and one in Computer Programming at the qualifying degree level OR Bachelor's degree and 3 years LLB/ Integrated program in LLB / Integrated program in management OR Post Graduate degree in Law

Qualifying Examination
 An entrance test conducted at selected few locations followed by an interview conducted jointly by the IIT and NLIU Bhopal.

Registration window opens-January 20, 2025
 Registration window closes-February 25, 2025
 Entrance Test- March 2, 2025
 Online classes will start from March 27, 2025

More details about the program can be found on the website: <https://cscl.iitb.ac.in>
 Contact- 0731-6603333-5593 Email id: office-cscl@iitb.ac.in

INDIAN INSTITUTE OF MANAGEMENT INDORE
 Prabandh Shikhar, Rau-Pithampur Road, Indore - 453556

NOTICE FOR ADMISSION INTO THE DOCTORAL PROGRAMME IN MANAGEMENT (DPM) - 2025

Specialization: Communication, Economics, Finance and Accounting, Humanities and Social Sciences, Information Systems, Marketing Management, Operations Management and Quantitative Techniques, Organizational Behaviour and Human Resource Management, Strategic Management.

Financial Support: Stipend of Rs. 40,000/- to Rs. 45,000/- per month, International Conference Grant of Rs. 2 Lakhs, National Conference Grant of Rs. 1.2 Lakhs, Research Development Grant of Rs. 1.5 Lakhs. Free boarding and lodging for the students.

Last date for submission of the online application form is **January 31, 2025**. For detailed information, please visit www.iimidr.ac.in

EQUIS ACCREDITED AACSB ACCREDITED AMBA ACCREDITED

EMPLOYMENT
GENERAL MULTIPLE VACANCIES

INDIAN INSTITUTE OF INSOLVENCY PROFESSIONALS OF ICAI
 (A Company formed by ICAI under Section 8 of the Companies Act 2013)

RECRUITMENT OF MANAGING DIRECTOR

Indian Institute of Insolvency Professionals of ICAI (IIPI), the largest Insolvency Professional Agency (IPA) in India, invites online applications from competent professionals for the position of **Managing Director (MD)**.

For further details such as eligibility criteria, educational qualification, Application Form etc., please visit the website of IIPI at <https://www.iiipicai.in>

Last date of Application : 26th February 2025

DELHI METRO RAIL CORPORATION LTD.
 (A Joint Venture of Govt. of India and Govt. of Delhi)

INDICATIVE ADVERTISEMENT

Delhi Metro Rail Corporation Ltd., The Lifeline of Delhi, invites application for the following post vide Advt. No. DMRC/PERS/22/HR (189):-

S. No.	Designation	No. of Post(s)	Pay scale/ Remuneration (in INR Scale)	Mode of Induction	Last date of Receipt of Application
1	Assistant Manager (Structural Health Monitoring & Instrumentation)	One (1)	₹ 50000-160000	Direct Recruitment	21.02.2025

The advertisement is only indicative. The detailed vacancy notification and particulars regarding the eligibility criterion, qualification, experience, age limit, mode of selection, etc., are available in the Career Section of the DMRC website: www.delhimetrorail.com

General Manager (HR) Project
 Delhi Metro Rail Corporation Ltd.
 Metro Bhawan, Fire Brigade Lane,
 Barakhamba Road, New Delhi

Advertisement No.: DMRC/958/2025

Approved by AICTE | Affiliated with Gujarat Technological University
DR. V. R. GODHANIA COLLEGE OF ENGINEERING & TECHNOLOGY

Managed by: Shri Maldevji Odedra Smarak Trust
 B/n. Amar Polyfills, Rajkot-National Highway, Opp. New Airport, Chhaya-360578, Dist.: Porbandar (Gujarat)
 Website : <http://drvget.ac.in>

Staff Recruitment

Sr. No.	Department	Director/Prinpal	Professor	Associate Professor / HOD	Assistant Professor / Lecturer
1	Management (MBA)		1	2	4
2	Civil Engineering		1	2	4
3	Computer Engineering		1	2	4
4	Mechanical Engineering	1	1	2	4
5	Diploma Computer Engg.		0	1	6
6	Diploma Civil Engg.		0	1	6
7	Diploma Mechanical Engg.		0	1	6
8	Physics		0	0	1
9	Mathematics		0	0	1
10	Chemistry		0	0	1

* Aspiring candidates should send the application along with requisite photocopies of certificates & resume by email to drvget@gmail.com as well as hard copy by speed post/registered ad to the above mentioned address with clearly readable post of applied and department on envelope cover.
 * Qualification, pay scale, experience and other service conditions are applicable as prescribed by GTU, Ahmedabad/AICTE.
 * Separate application for each post in necessary.
 * The last date of receiving application is **21-02-2025**
 Note : Eligible applicants will be invited for interview with scrutiny panel at Porbandar (Gujarat). Date & Venue for the same will be intimated through E-Mail/Call in well advance.

Dr. Virambhal R. Godhanla
 (President)

Organised by IDEMI Mumbai, Ministry of MSME, Govt. of India
Government Certificate Course on GENERATIVE AI AND LLM

Course Timing: 10.00 AM To 1.00 PM
(ONLINE)
 15th, 16th, 22nd, 23rd Feb 2025
 Duration: 4 Days

COURSE FEES: ₹. 8000/- +18% GST

Email: training@idemi.org website: <https://idemi.org/>

HANDS ON EXERCISES & LEARNING

What you will learn: Generative AI and LLM, Fundamental of Generative AI system, Common tools and frameworks of Gen AI connect, Type of Models and use the Gen AI, National MSME Schemes and initiatives

Who can attend: Any student / professional with basic computer programming knowledge can join the course.

After Successful completion certificate will be issued
 Scan QR Code for Registration & Fees Payment

Contact no. 7738184063 / 8879774348 / 9869087617

SBI
 State Bank of India
 Central Recruitment & Promotion Department
 Corporate Centre, Mumbai
 Phone: 022-22820427

Scan QR to Apply

Recruitment of Specialist Cadre Officers on Regular/Contractual Basis

Applications are invited from Indian citizens for the following post on Regular/Contractual basis:

Sl. No.	Name of Post	Vacancy	Type
Advertisement No.: CRPD/SC/2024-25/29			
1	Chief Officer (Security)	01	Contractual
Advertisement No.: CRPD/SC/2024-25/27			
1	Manager (Data Scientist)	12	Regular
2	Deputy Manager (Data Scientist)	28	Regular

For eligibility criteria (age, experience, job profile etc.), vacancy details, requisite fee and other details, log on to Bank's website <https://bank.sbi/web/careers/current-openings> for online submission of application as well as online payment of application fee. Refer detailed advertisement to ensure eligibility and other details before applying and remitting fees. For any query, please write to us through link "CONTACT US" - "Post Your Query" which is available on Bank's official website (<https://bank.sbi/web/careers/post-your-query>)

DATE FOR FILING ONLINE APPLICATION & PAYMENT OF FEES:
 FROM 01.02.2025 to 24.02.2025.

Place: Mumbai
 Date: 01.02.2025
 General Manager (RP & PM)

Parul University
 Vadodra, Gujarat
 NAAC GRADE A++

DIRECTOR DEPUTY DIRECTOR INTERNATIONAL RELATIONS

The university is seeking a qualified professional for the position of Director & Deputy Director - Centre for International Relations and Research (CIRR). The incumbent will lead international collaborations, establish global partnerships, and manage key academic initiatives such as summer schools and semester exchanges. This role focuses on enhancing the university's global presence and fostering cross-cultural learning. Applicants are requested to review the experience and eligibility criteria in the link before applying.

Interested candidates can apply through www.paruluniversity.ac.in/careers within 15 days of this advertisement.

ISB&M
 International School of Business & Media
 Pune : Nande-Mulshi | Kolkata | Bangalore
 Pune's 2nd Most Preferred B-School

18 Lacs
 Vedit (2022-24)
 Legacy of High Career Performance
GD&PI
 AICTE Approved

Mumbai 20th Feb. The Orchid, Vile Parle (E) Mumbai
 Pune 22nd & 23rd Feb. ISB&M Pune Nande Campus
 Enquire Now 7757029571 / 020 35012000 www.isbm.ac.in

SAPTHAGIRI NPS UNIVERSITY
 UNMATCHED EXCELLENCE, UNLIMITED POTENTIAL
 BANGLORE, KARNATAKA

Walk-In Drive

Position: Faculty for Computer Science Engineering

- Assistant Professor (Fresh M. Tech CSE | ISE Graduates Welcome)
- Associate Professor
- Professor

LOCATION

9th Feb 2025 - 10:00 AM to 5:00 PM
 Coimbatore: Ibis Coimbatore City Centre, Lakshmi Mills Junction, Puliakulam Rd, Coimbatore, Tamil Nadu - 641037

16th Feb 2025 - 10:00 AM to 5:00 PM
 Mysuru: Maya's Kings Kourt, Jhansi Rani Lakshmi Bai Rd, Devaraja Mohalla, Shivarampet, Mysuru, Karnataka - 570005

Eligibility Criteria: As per AICTE norms.

How to Apply: Interested candidates are invited to attend the walk-in interview with a copy of their updated CV, Academic Certificates & Work Experience Certificate, Research Publications, Passport Size Photos and Photo Identity Proof Document.

For more details Contact
 Phone: 98862 56888 | Email: hr@snpnu.edu.in

Government Medical College, Pithoragarh & Associate Hospital, Linthura, Pithoragarh 262501, Uttarakhand

Email: gmc-pithoragarh@gmail.com Phone No. 9837251413
 @gmc-pithoragarh

No. GMCP/Advt./Recruitment/2024-25/ Date: 05.02.2025

5th ROLLING MEDICAL FACULTY ADVERTISEMENT
 Advt. No.: GMCP/Advt./Recruitment/2024-25/

Offline applications are invited for the medical faculty posts on direct recruitment/deputation basis in various departments at Government Medical College, Pithoragarh & Associate Hospital, Pithoragarh, Uttarakhand. A "Walk-In-Interview" will be held on 27th February, 2025 (Thursday) from 11:00 AM onwards in "Principal Office, Government Medical College, Haldwani, Rampur Road, Haldwani, Nainital, Uttarakhand. For Further information candidates are requested to visit the website of medical education on regular basis-<https://medical.education.uk.gov.in/>

Principal
 Government Medical College, Pithoragarh

Dr. Sagar Mal Juniwal's APEX UNIVERSITY
 Recognized u/s 2(f) of the UGC Act, 1956

ADMISSION NOTIFICATION Ph.D. PROGRAMME

Applications are invited for admission to the Ph.D. Programme (Full Time/Part Time) for the session 2024-25 for January 2025 (Intake) at Apex University, Jaipur in various disciplines (Details available at <https://www.apexuniversity.co.in/research.php>) Admission will be made through Entrance Test/NET & Personal Interview as per UGC Regulations, 2022.

Last Date for submission of online application 15th February 2025
<https://admissions.apexuniversity.co.in>
 Entrance Test Date 22nd February 2025

Call : 74138 74138 | 0141-6660999

AMRITA
 Come. Become.

WE MAKE YOU BE WHO YOU WANT TO BE
 2025 APPLICATIONS OPEN FOR B.TECH., M.TECH. & MBA

MBA PROGRAMS
 100% Scholarship for AICTE Rank Holders
 93.62% Placement in 2024
 ₹2190 Per Month CTC
 ₹2.4 Lacs CTC

Apply with:
 AICTE | GATE | XAT | MAT | CMAT | GMAT | GRE

M.TECH. PROGRAMS
 Apply with:
 AICTE | GATE | XAT | MAT | CMAT | GMAT | GRE

B.TECH. PROGRAMS
 Apply with:
 AICTE | GATE | XAT | MAT | CMAT | GMAT | GRE

Use 75% fee waiver
 ₹156.95 Per Month CTC
 ₹2.4 Lacs CTC

Enquire Now
 0476-2405555

Tech-Perfect Solutions for the Nation's Defence

BHARAT ELECTRONICS LIMITED
 (A Govt. of India Enterprise under the Ministry of Defence)
 (CIN: L32309KA1954GOI000787)

Bharat Electronics Limited, which is a Navaraina Company & India's premier Professional Electronics Company, requires following professional on Temporary basis for its Product Development and Innovation Centre (PDIC) & Centres of Excellence (CoE) at Bengaluru.

Sl. No.	Post	Post / Grade	Discipline	No. of Posts	Upper age limit (as on 01.01.2025)
1	Temporary Basis	Project Engineer-I	Electronics	43	32 Years
		BE/B.Tech/B.Sc Engineering	Mechanical	18	
2	Temporary Basis	Traineee Engineer-I	Computer Science	08	28 Years
			Mechatronics	01	
		BE/B.Tech/B.Sc Engineering	Electronics	42	
			Mechanical	20	
		Computer Science	05		

For detailed advertisement visit our web-site www.bel-india.in (careers/recruitment).

'Har Ek Kaam Desh Ke Naam'

PRINCIPAL'S DESK – A PLATFORM FOR EDUCATIONAL INSIGHTS AND OPPORTUNITIES

The Principal's Desk at epaper.VidyarthiMitra.org is a dedicated space designed to serve as a hub of knowledge-sharing and collaboration for educators, academic leaders, and administrators. This platform provides an opportunity for institutions to share valuable insights, important announcements, and academic opportunities with a broad audience that includes students, parents, and fellow educators. By fostering a culture of collaboration, the Principal's Desk allows colleges, universities, and educational institutions to contribute articles and updates that are of relevance to the academic community.

For institutions looking to highlight their unique offerings, faculty achievements, new programs, or institutional milestones, this platform serves as the ideal avenue to showcase their strengths. Whether it is about reaching prospective students, announcing new courses, or sharing details about scholarships and internships, the Principal's Desk helps institutions effectively engage with the right audience. Additionally, institutions can provide information about admission procedures, campus events, faculty contributions, and other academic initiatives, thereby ensuring greater visibility and outreach.

For those seeking talented individuals to fill job vacancies, faculty positions, or internship opportunities, the Principal's Desk is an effective medium to connect with aspiring candidates looking for career growth in the education sector. By sharing details about job openings, eligibility criteria, application deadlines, and recruitment procedures, institutions can attract skilled and qualified professionals who align with their academic vision.

Submitting an article or announcement is a simple and straightforward process. Institutions need to send their content along with relevant images or graphics to the editorial team at info@vidyarthimitra.org, where it will be reviewed for publication in the next edition. The platform adheres to guidelines that ensure content is fact-based, grammatically accurate, and free from plagiarism, thus maintaining high editorial standards.

Sincerely,
Mr. Ravindra Kamtam
Editor-in-Chief
epaper.VidyarthiMitra.org

Riddles

I house young minds, eager to grow,
With lessons and knowledge, they soon will know.

Desks and chairs, a learning space,
Where am I? Find my place!

Answer: A Classroom

I hold knowledge, page by page,
With stories, facts, and wisdom of age.
Open me up, and you will see,
A world of learning inside of me.

Answer: A Book

I come in numbers, I come in words,
A test of knowledge, skill, and nerves.
You write me down, on paper so neat,
Who am I, where students compete?

Answer: An Exam

I guide you well, through right and wrong,
With lessons that help you grow up strong.

I stand before you, chalk in hand,
In this learning journey, by you I stand.

Answer: A Teacher

I have hands but do not clap,
I tell you time without a nap.
In schools, I help you keep in line,
Tick-tock, what's my sign?

Answer: A Clock

I have seats but I'm not a car,
I take students near and far.
Bright and yellow, I'm easy to see,
What am I, transporting thee?

Answer: A School Bus

STUDENT CORNER – YOUR VOICE MATTERS

Your Voice Matters!

Dear Students,

The Student Corner at epaper.VidyarthiMitra.org is an exclusive space designed to empower students by providing them with a voice to express their thoughts, share their concerns, and seek academic guidance. Navigating the educational landscape can often be challenging, especially with the vast amount of information available on college admissions, entrance exams, reservation policies, syllabus requirements, and studying abroad. This section is tailored to address such concerns, allowing students to ask queries related to education in India and overseas, with a team of experts striving to provide them with accurate, insightful, and well-researched responses.

Submitting queries, opinions, or experiences is simple—students can email their content to info@vidyarthimitra.org, where the editorial team will review it for potential publication. In addition to seeking answers, students are encouraged to engage with fellow readers by participating in discussions, exchanging feedback, and sharing their academic experiences. This space is not just an information hub but a community-driven platform where students can connect, collaborate, and grow together while navigating their unique educational journeys.

By fostering an interactive and supportive environment, the Student Corner ensures that students feel heard, valued, and motivated throughout their academic paths. Whether they seek guidance, wish to contribute insights, or simply want to engage in constructive discussions, this platform provides them with the opportunity to be active participants in shaping the academic discourse. Education is a journey, and through the Student Corner, students can feel assured that they have a dedicated space where their voices truly matter.

Best Regards,
Mr. Ravindra Kamtam
Editor-in-Chief
epaper.VidyarthiMitra.org

EDITORIAL

Introducing Epaper.VidyarthiMitra.org: Empowering Students Through Knowledge

Epaper.VidyarthiMitra.org is a beacon of knowledge, guidance, and empowerment for students. It's a Pune-based education consultancy committed to democratizing education access and empowering every student to reach their full potential. Offering comprehensive resources for students, parents, educators, and stakeholders, it bridges the gap between aspirations and achievements.

With years of dedication and expertise in higher and professional education, VidyarthiMitra.org has evolved into a platform offering mock exams, career assessments, and admission guidance. The epaper takes this commitment further by providing accessible, informative, and inspiring content. From current affairs to entrance exam updates, admission guidance to scholarship opportunities, and career advice to student success stories, Epaper.VidyarthiMitra.org is a treasure trove of knowledge and inspiration, ensuring a future filled with growth and opportunity for all.

Mr. Ravindra Kamtam
Editor-in-Chief
epaper.VidyarthiMitra.org



Empowering Educational Opportunities with VidyarthiMitra.org: Your Comprehensive Educational Companion

In the dynamic landscape of education, **VidyarthiMitra.org** stands as a guiding light, offering a holistic array of services meticulously crafted to cater to the diverse needs of aspiring learners. Our platform boasts an extensive database of **top universities, colleges, and courses of Maharashtra, India and Abroad**. By providing detailed insights into each institution to facilitate well-informed decision-making. We streamline the **admission process** with step-by-step **guidance** and a comprehensive **government document checklist**, ensuring clarity and organization throughout. Stay ahead with our up-to-date information repository on **entrance exams**, coupled with **mock tests** and **detailed syllabus** to bolster your preparation. Dive into our rich repository of **study materials**, including **mock tests, solved papers**, and comprehensive study

material, designed to enhance your exam readiness. Gain valuable insights into cutoff trends and fee structures, empowering strategic college selection and financial preparedness. Our personalized **career guidance** services offer tailored support, including **career assessment tests** and **admission assistance**, while our study abroad services facilitate seamless transitions into international education. Stay informed with our empowering educational **news portal** and **epaper**, covering **current affairs, entrance exam updates, admission, and scholarship opportunities**. In essence, VidyarthiMitra.org transcends being just a platform; it's a transformative educational ecosystem dedicated to empowering learners and shaping futures, inviting you to embark on a journey towards academic excellence and success.

विद्यार्थी मित्र

VidyarthiMitra.org

CAREER PATH FINDER (as per New Education Policy)

10th (S.S.C.)

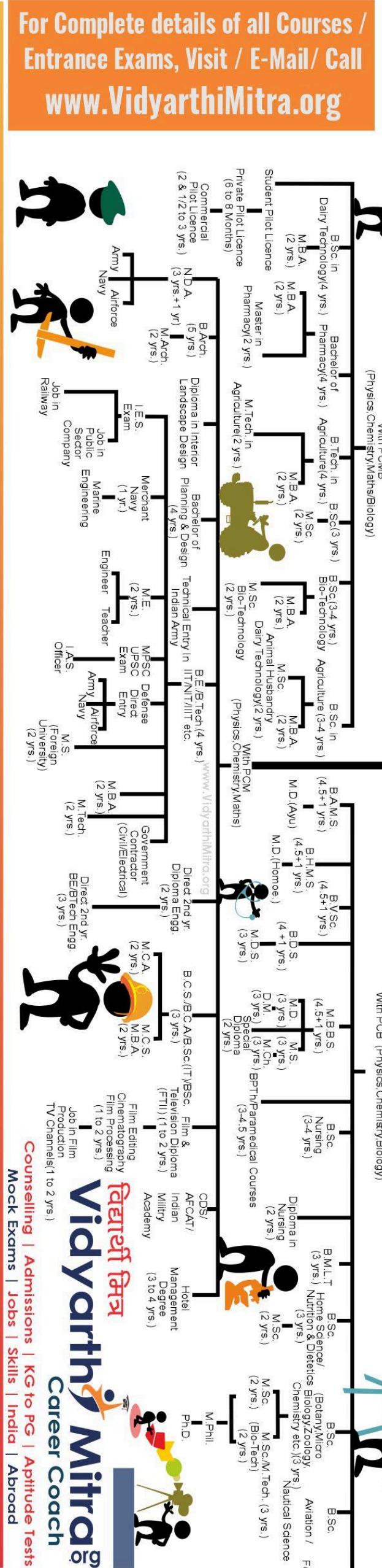
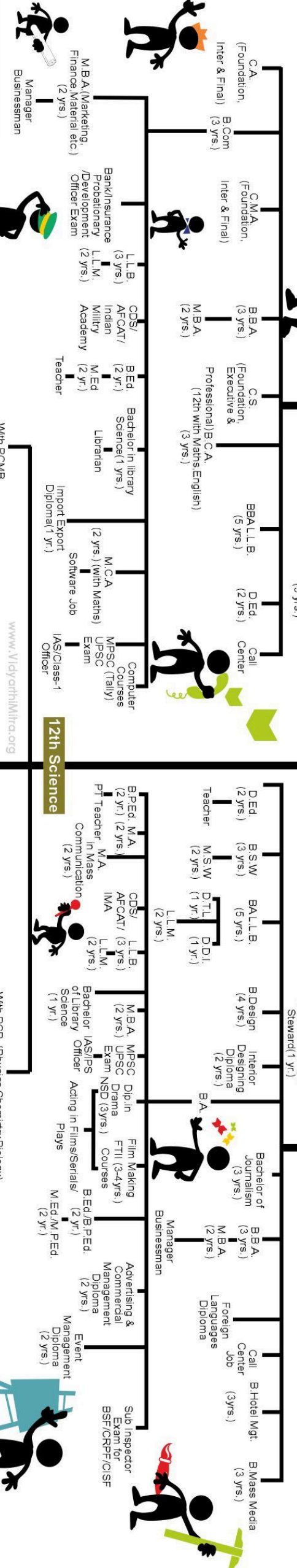
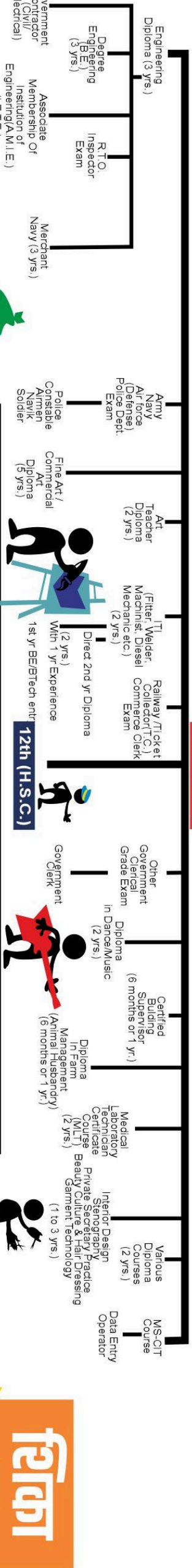

For Complete details of all Courses / Entrance Exams, Visit / E-Mail/ Call

www.VidyarthiMitra.org

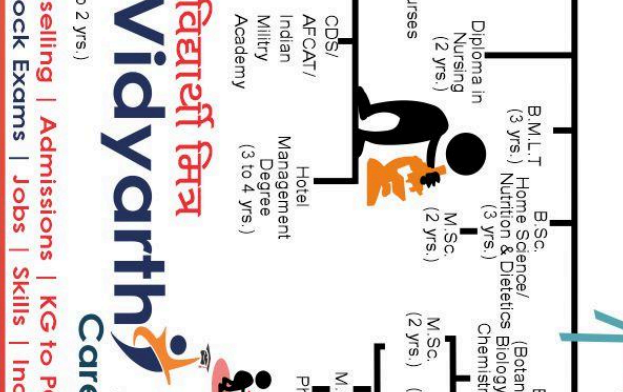
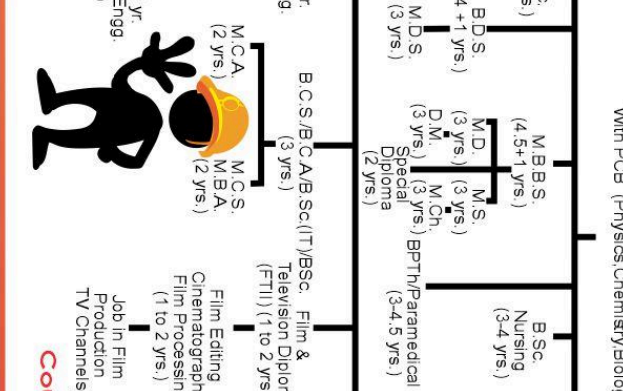
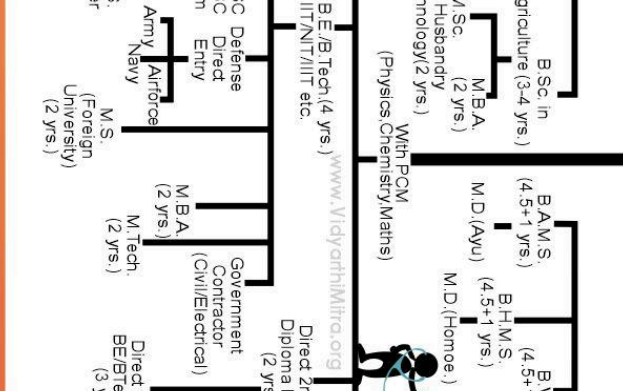
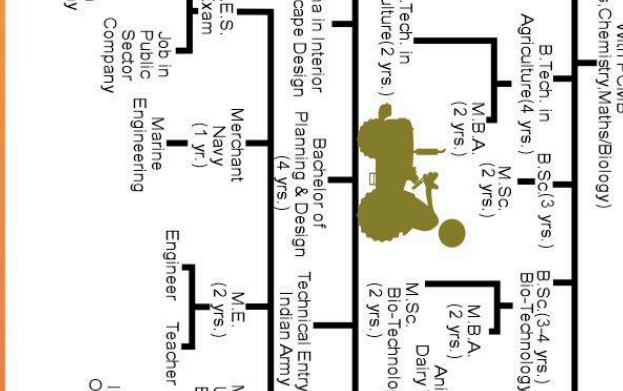
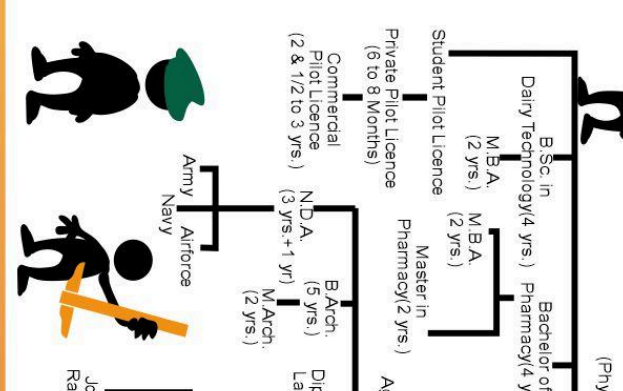

+91 77200 25900 info@VidyarthiMitra.org

VidyarthiMitra.org

Career Coach

Counselling | Admissions | KG to PG | Aptitude Tests

Mock Exams | Jobs | Skills | India | Abroad